

BAKERY CASE RECTANGLE 직각 베이커리 케이스



SB1500-2RD



2단 (Layer)

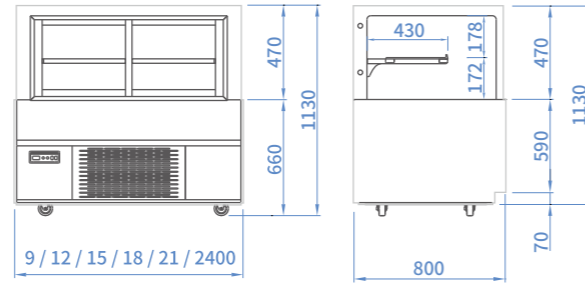

SB1500-4RD



4단 (Layer)

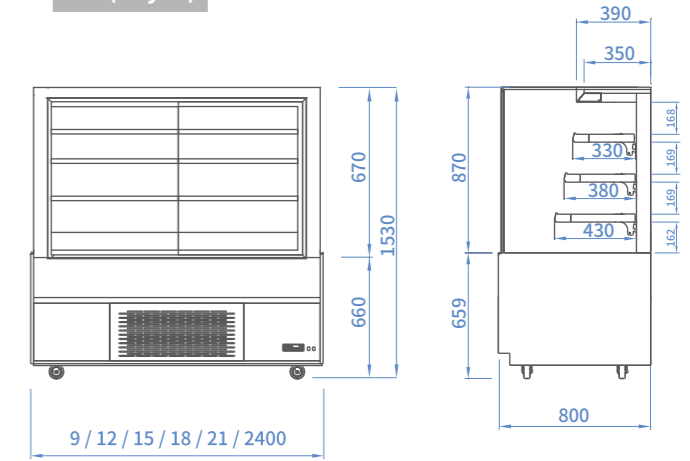

SB900-2RD

SB1200-2RD

SB1800-2RD

SB2100-2RD

SB2400-2RD



SB1500-3RD



3단 (Layer)

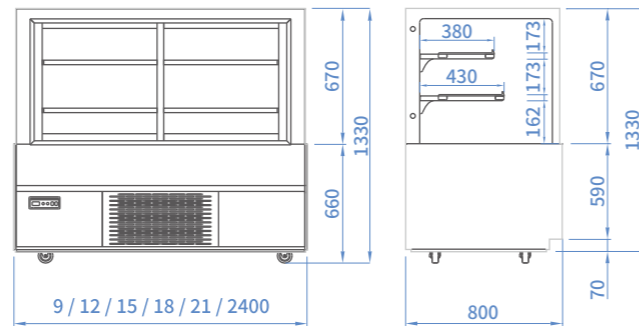

SB900-4RD

SB1200-4RD

SB1800-4RD

SB2100-4RD

SB2400-4RD



SB900-3RD

SB1200-3RD

SB1800-3RD

SB2100-3RD

SB2400-3RD



모델명 / MODEL	SB900-3RD	SB1200-3RD	SB1500-3RD	SB1800-3RD	SB2100-3RD	SB2400-3RD
분류 / Classification	냉장 (Refrigerator)					
외형치수 / Cabinet dimension (WxDxH mm)	900 / 1200 / 1500 / 1800 / 2100 / 2400 x 800 x 1130 (2단)/1330(3단)/1530(4~5단)					
용량 / Capacity (ℓ)	270	376	505	590	706	823
온도 범위 / Inner Temperature (°C)	3 ~ 8					
냉매 / Refrigerant	R-134a	R-134a	R-404a	R-404a	R-404a	R-404a
단열 방식 / Insulation Type	폴리우레탄 (Polyurethane) / 싸이클로펜탄 (Cyclopentane) + CFC Free					
정격 입력력 / Power (W)	488	515	684	802	804	915
전원 / Voltage (V/Hz/Ph)	220 / 60 / 1					
중량 / Weight (Kg)	190	240	280	300	340	400
문 타입 / Door type	슬라이딩 도어 (Sliding door)					
문 수량 / # of doors	2	2	2	2	3	3
컴프레서 / Compressor (HP)	1/3	1/3	1/2	1	1	1
선반 수량 / # of Shelves	1 (2단) / 2 (3단) / 3~4 (4~5단)					